

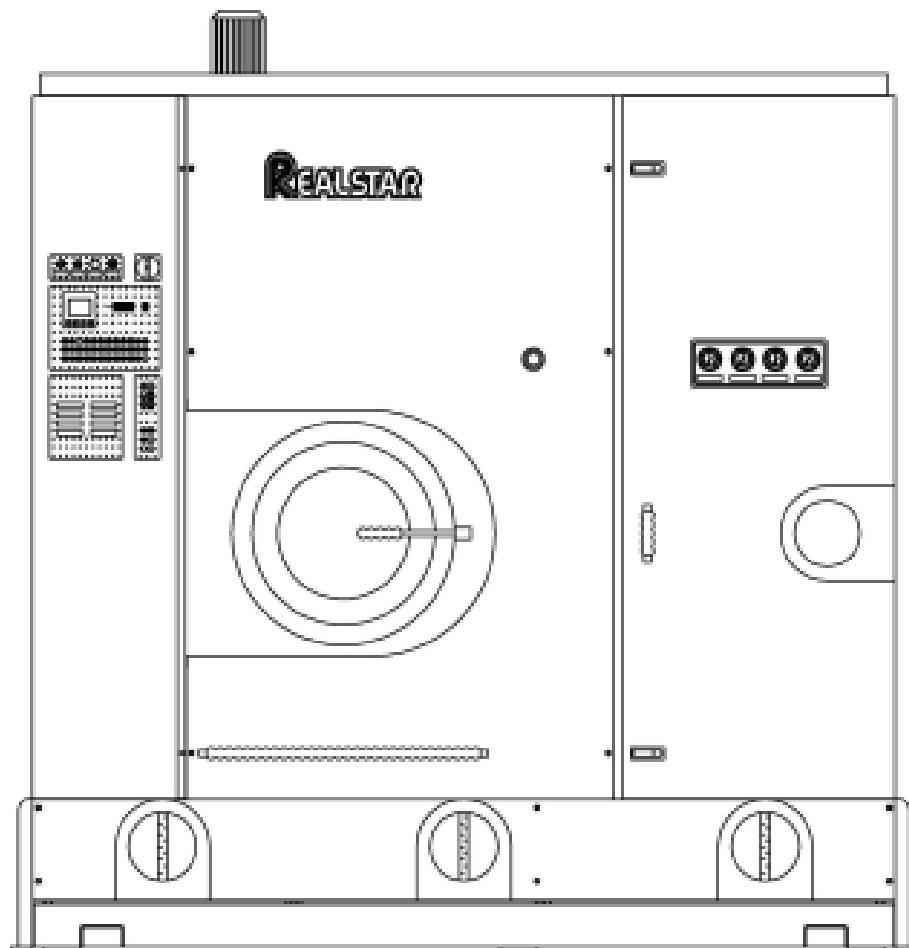

MACCHINE LAVASECCO - DRY CLEANING MACHINES

TECHNICAL INFORMATION



KM703



TECHNICAL INFORMATION

WORKING MACHINE WITH SOLVENT:	HYDROCARBON	
MACHINE CAPACITY (RATIO 1:20)	Lbs	75 ÷ 80

BASKET

Diameter	inches	47.3
Depth	inches	22.5
Volume	cu-ft	22.8
Wash speed	rpm	12 ÷ 50
Extract speed	rpm	300 ÷ 450
Door opening	inches	20

SOLVENT TANKS

Useful volume tank 1	gal	63.4
Useful volume tank 2	gal	63.4
Useful volume tank 3	gal	87.2
FLOOR SAFETY TANK CAPACITY	gal	145



DESTILLATOR

Useful volume at half inspection	gal	95
Total volume	gal	120

ELECTRIC POWER (220 V - 60 Hz)

Wash motor - Extract motor (with Inverter)	Hp	8.1	Kw	6.1
Solvent pump motor	Hp	1.5	Kw	1.1
Fan motor	Hp	5.5	Kw	4.1
Refrigerator compressor MT81	Hp	6.5	Kw	4.85
Nylon filter motor	Hp	0.75	Kw	0.55
Vacuum pump motor 1/2	Hp	0.5 x 2 = 1	Kw	0.38 x 2 = 0.76
Still electric elements	Hp	0.5	Kw	0.38
Heater electric elements				
Air motor compressor				

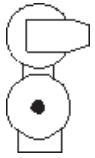
NOTE: Acoustic emission level of the machine is lower than 70 dB (A)

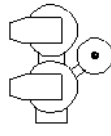
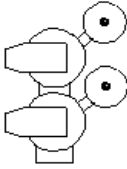
FILTRATION AVAILABLE IN THIS MODEL			
Version	ONE NYLON FILTER AND ONE CARTRIDGE - KR		
	Volume nylon filter housing	gal	20
	Nylon filter area	ft ²	60
	Filter disks	nr	39
	KR Decolorating housing volume	gal	22.5
	KR Decolorating filter	ft ²	28 x 3 = 84
	KR cartridges quantity	nr	3
Version	ONE NYLON ONE CARTRIDGE - KR ONE DECOLORATING PR		
	Volume nylon filter	gal	20
	Nylon filter area	ft ²	60
	Filter disks	nr	39
	KR Decolorating housing volume	gal	22.5
	KR Decolorating filter area	ft ²	28 x 3 = 84
	KR Decolorating cartridges	nr	3
	PR - Deco filter volume	gal	6.6
	Tubes	nr	1
	PR - Cartridge quantity	nr	2
	Decolorating carbon quantity	Lbs	8.8
Version	TWO NYLON FILTERS AND ONE DECOLORATING FILTERS		
	Volume nylon filter housing	gal	20 x 2 = 40
	Nylon filter area	ft ²	60 x 2 = 120
	Filter disks	nr	39 x 2 = 78
	PR - Deco filter volume	gal	6.6
	Tubes	nr	1
	PR - Cartridge quantity	nr	2
	Decolorating carbon quantity	Lbs	8.8
Version	TWO NYLON FILTERS AND TWO DECOLORATING FILTERS - PR		
	Volume nylon filter housing	gal	20 x 2 = 40
	Nylon filter area	ft ²	60 x 2 = 120
	Filter disks	nr	39 x 2 = 78
	PR - Deco filter volume	gal	6.6 x 2 = 13.2
	Tubes	nr	2
	PR - Cartridge quantity	nr	4
	Decolorating carbon quantity	Lbs	17.6

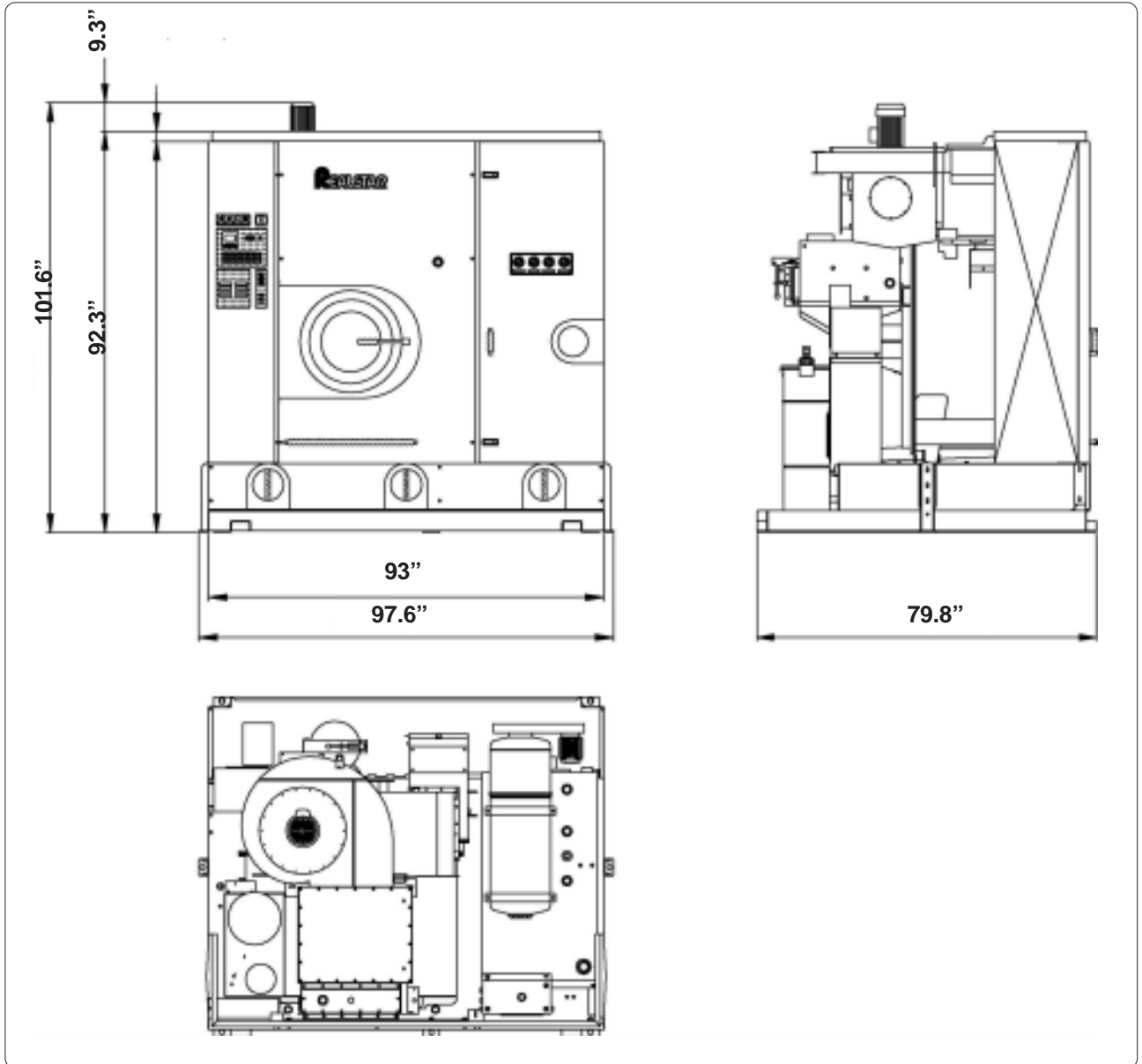
DIMENSIONS AND WEIGHTS

CHARGES		
Empty machine weight	Lbs	6260
Machine weight with solvent	Lbs	7980
Static charge on the floor with solvent	Lbs/ft ²	155
Dynamic charge on the floor (+10%)	Lbs/ft ²	234

PACKAGED MACHINE DIMENSIONS AND WEIGHTS

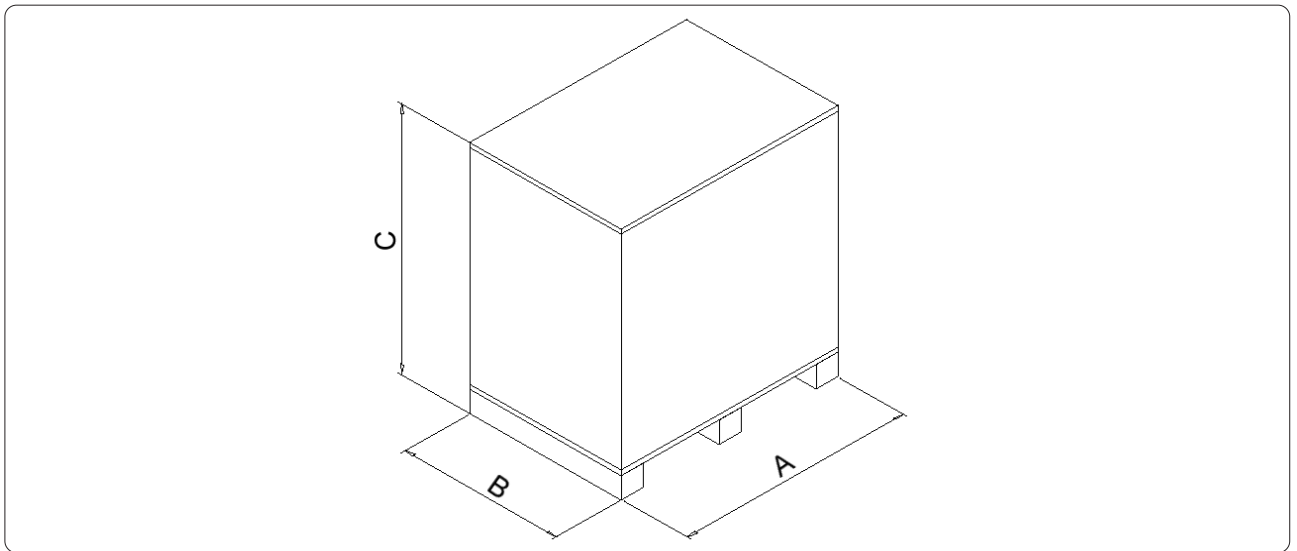

PACKAGED MACHINE DIMENSIONS				
Machine type		Carton	Wooden cage	Wooden case
KM703	A		inches 101.6"	
	B		inches 87.8"	
	C		inches 97.6"	

PACKAGED MACHINE WEIGHTS				
Machine type		Carton	Wooden cage	Wooden case
KM703			Lbs 7098	



FIXING POINTS

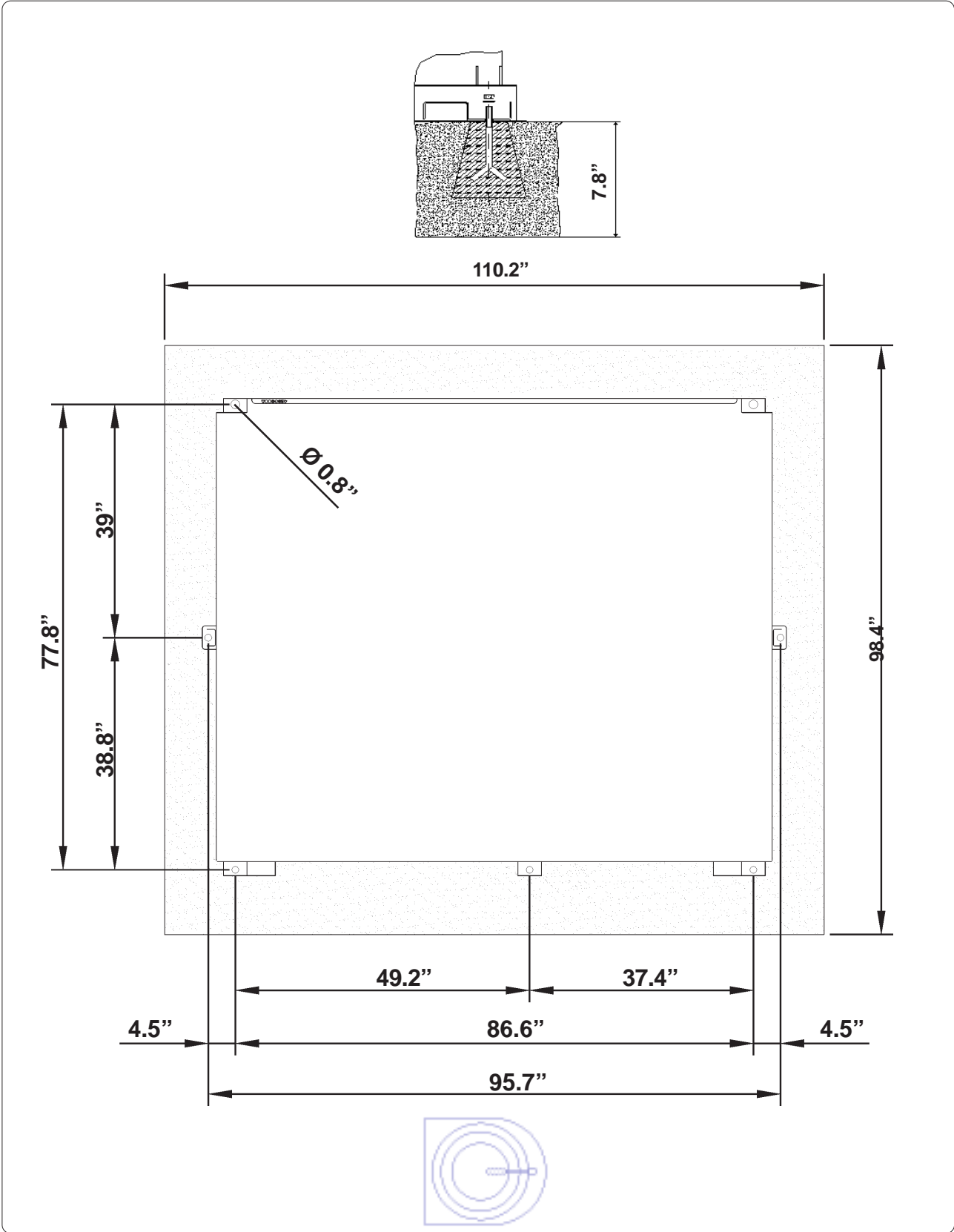

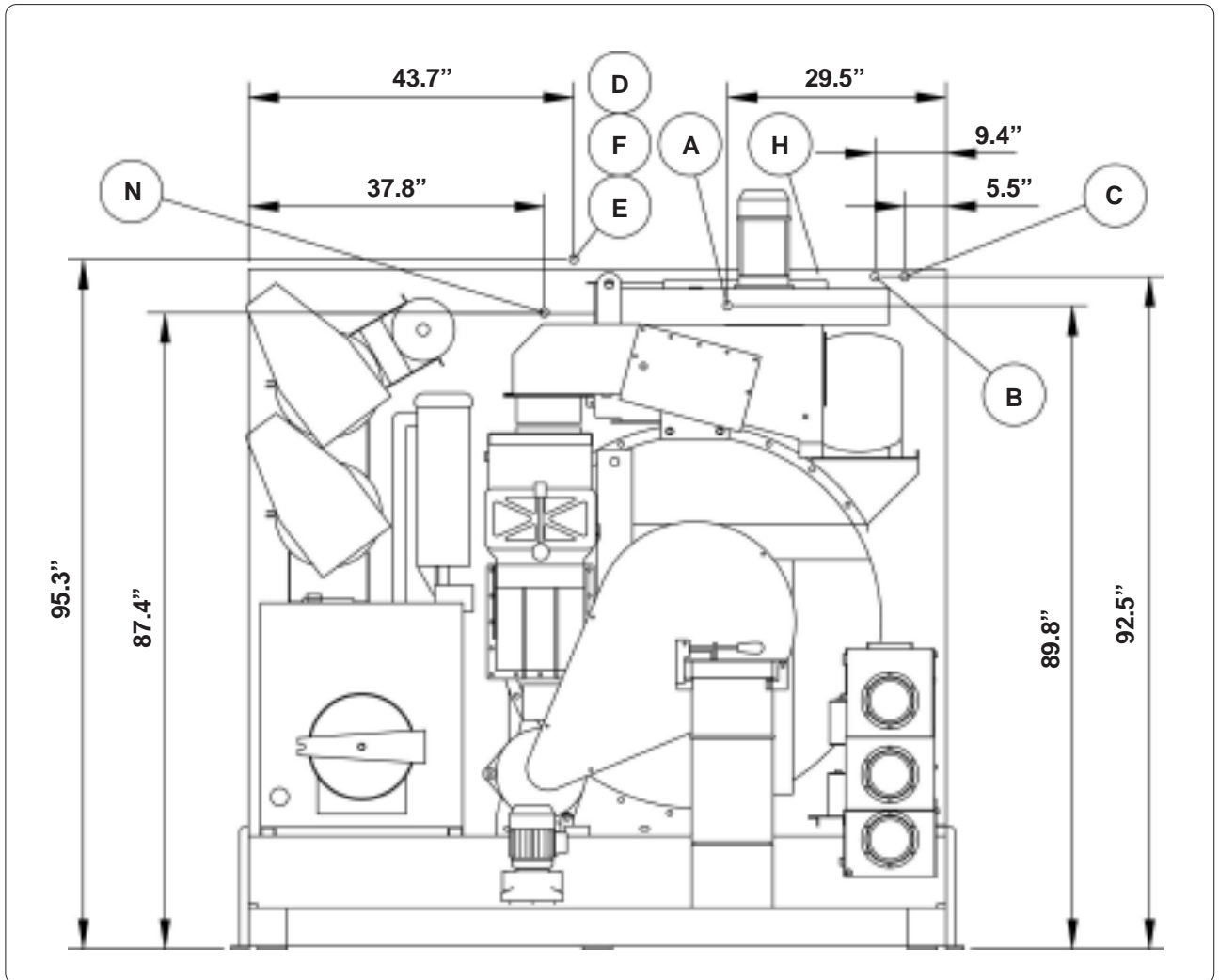
CONNECTIONS

A	Compressed air inlet	Ø 6 mm / 1/4"
B	Water inlet	Ø 1"
C	Water outlet	Ø 1"
D	Steam still inlet	Ø 1/2"
E	Condensate still outlet	Ø 1/2"
F	Steam heater inlet	Ø 1/2"
-	-	-
H	Electric connection	
N	Nitrogen feeding connection (N ₂)	



USEFUL INSTALLATION INFORMATION

SOLVENT TYPE		HYDROCARBON		
NECESSARY QUANTITY OF SOLVENT TO FILL THE MACHINE				
Machine Version - 1 NYLON F. + 1LARGE CARTRIDGE	gal	256	Lbs	1647
Machine Version - 1 NYLON F. + 1 CARTRIDGE + 1 DECO F.	gal	263	Lbs	1689
Machine Version - 2 NYLON F. + 1 DECOLORATOR F.	gal	260	Lbs	1671
Machine Version - 2 NYLON F. + 2 DECOLORATOR F.	gal	267	Lbs	1715

INFORMATION FOR THE ELECTRICAL CONNECTIONS (220 V - 60 Hz)				
ELECTRIC Version	Kw	-	Amp	-
STEAM Version	Kw	17	Amp	90.5

GENERAL INFORMATION		
Required water capacity	gal/min	3
Required water pressure	psi	40 ÷ 70
Required water temperature	°F	65° ÷ 70°
Required air pressure	psi	100 ÷ 115
Required steam pressure (Steam Version)	psi	55 ÷ 70
Required steam availability (Steam Version)	Lbs/h	220

All technical data are subject to change without notice.