

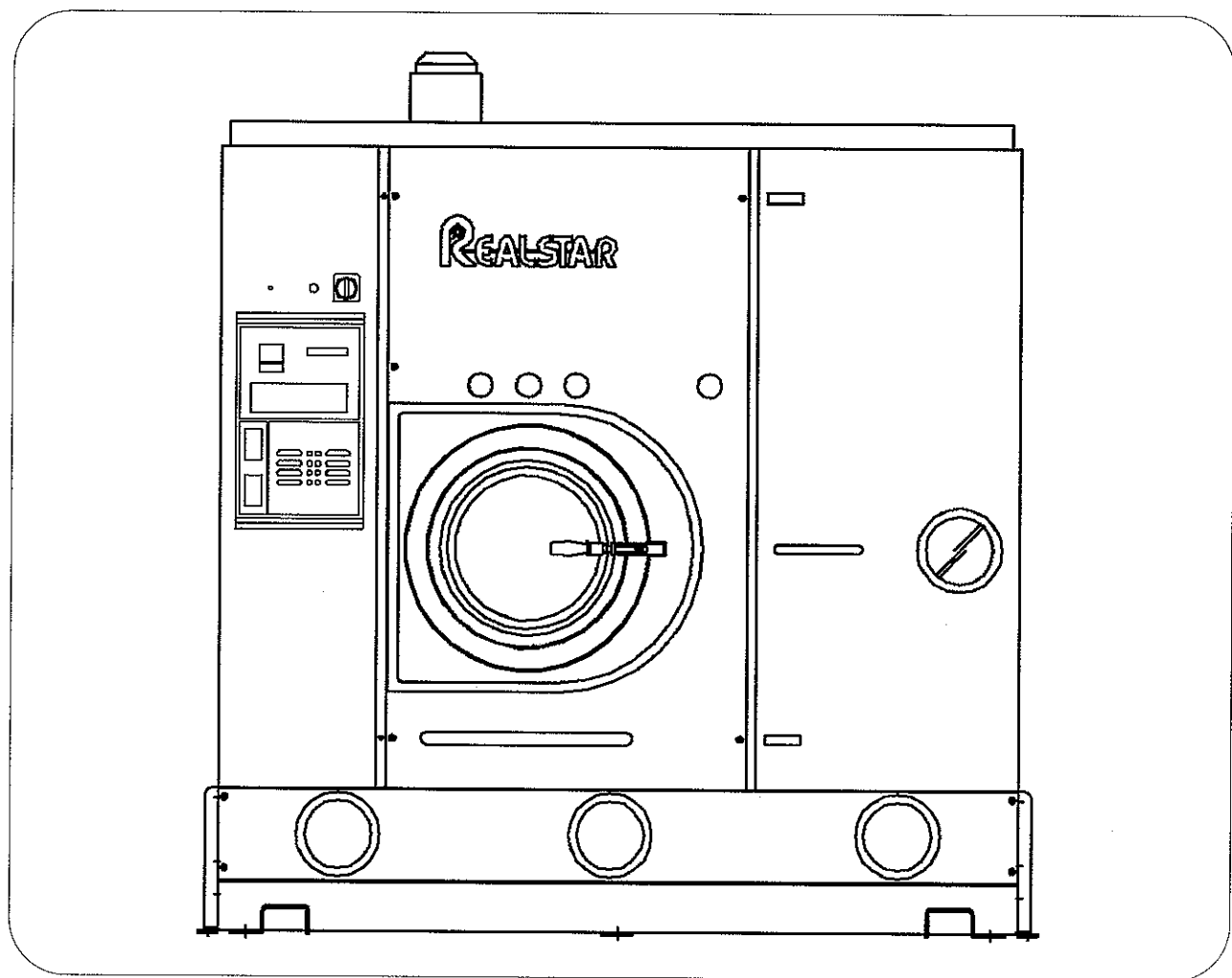

MACCHINE LAVASECCO - DRY CLEANING MACHINES

TECHNICAL INFORMATION





TECHNICAL INFORMATION

WORKING MACHINE WITH SOLVENT:	HYDROCARBON	
MACHINE CAPACITY (RATIO 1:20)	Lbs	40

BASKET

Diameter	inches	35.4
Depth	inches	21
Volume	gal	90
Wash speed	rpm	12 ÷ 50
Extract speed	rpm	300 ÷ 540
Door opening	inches	20

SOLVENT TANKS

Useful volume tank 1	gal	29
Useful volume tank 2	gal	29
Useful volume tank 3	gal	53

FLOOR SAFETY TANK CAPACITY	gal	95
-----------------------------------	-----	----

STILL

Useful volume at half inspection	gal	50.2
Total volume	gal	60.8
Boiler water capacity	gal	1.4

ELECTRIC POWER (220 V - 60 Hz)

Wash motor - Extract motor	Hp	3	Kw	2.25
Solvent pump motor	Hp	1	Kw	0.75
Fan motor	Hp	3	Kw	2.25
Refrigerator compressor	Hp	5	Kw	3.75
Nylon filter motor	Hp	0.75	Kw	0.55
Vacuum pump motor	Hp	3	Kw	2.25
Still electric elements	Hp		Kw	3 x 2.5 = 7.5
Heater electric elements	Hp		Kw	6 x 2.5 = 15
Air motor compressor	Hp	0.5	Kw	0.37

NOTE: Acoustic emission level of the machine is lower than 70 dB (A)

FILTRATION AVAILABLE IN THIS MODEL			
Version - 04	ONE NYLON FILTER AND ONE LARGE CARTRIDGE - KR		
	Volume nylon filter housing	gal	14.5
	Nylon filter area	ft ²	42
	Filter disks	nr	26
	Volume large cartridge housing - KR	gal	14.5
	Area large cartridge	ft ²	28 x 2 = 56
	Cartridges quantity	nr	2
Version - 08	ONE NYLON FILTER AND ONE DECOLORATING FILTER		
	Volume nylon filter housing	gal	14.5
	Nylon filter area	ft ²	42
	Filter disks	nr	26
	Decolorating housing volume	gal	6.6
	Decolorating cartridges	nr	2
	Decolorating cabon quantity	Lbs	8.8
Version - 10	ONE NYLON ONE CARTRIDGE -KR ONE DECOLORATING		
	Volume nylon filter	gal	14.5
	Nylon filter area	ft ²	42
	Filter disks	nr	26
	Volume large cartridge housing - KR	gal	14.5
	Area large cartridge	ft ²	28 x 2 = 56
	Cartridge quantity	nr	2
	Volume decolorating housing	gal	6.6
	Tubes	nr	1
	Cartridge quantity	nr	2
	Decolorating carbon quantity	Lbs	8.8
Version - 11	TWO NYLON FILTER AND ONE DECOLORATING FILTER		
	Volume nylon filter housing	gal	14.5 x 2 = 29
	Nylon filter area	ft ²	42 x 2 = 84
	Filter disks	nr	26 x 2 = 52
	Volume decolorating housing	gal	6.6
	Tubes	nr	1
	Cartridge quantity	nr	2
	Decolorating carbon quantity	Lbs	8.8

DIMENSIONS AND WEIGHTS

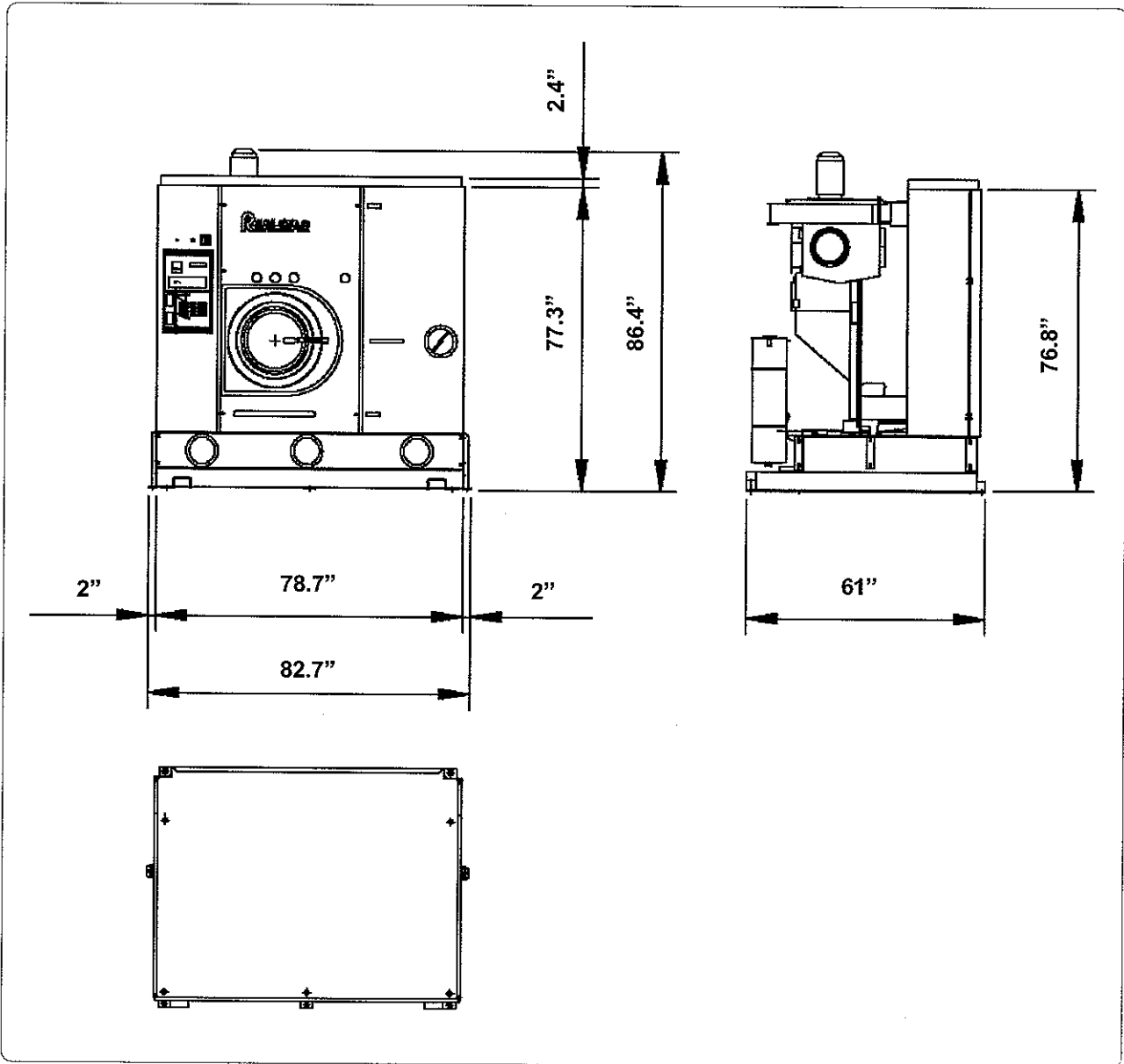

CHARGES		
Empty machine weight	Lbs	4035
Machine weight with solvent	Lbs	5269
Static charge on the floor with solvent	Lbs/ft ²	158
Dynamic charge on the floor (+10%)	Lbs/ft ²	208

PACKAGED MACHINE DIMENSIONS AND WEIGHTS

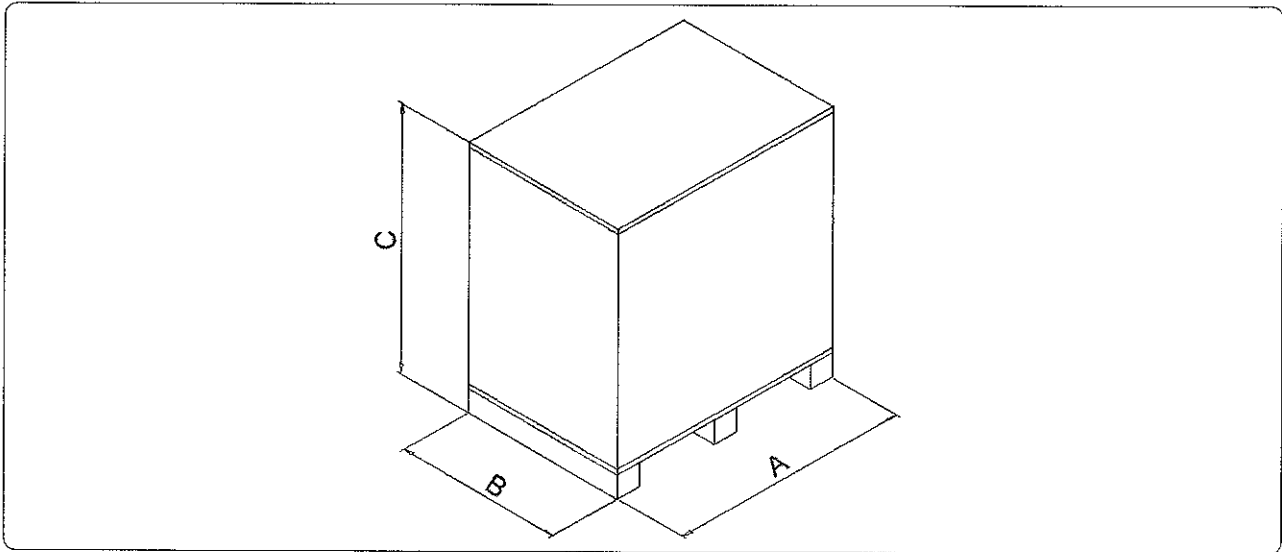

PACKAGED MACHINE DIMENSIONS				
Machine type		Carton	Wooden cage	Wooden case
KM343	A	inches 88.2	inches 89.8	
	B	inches 78.3	inches 74.8	
	C	inches 96.1	inches 96.1	

PACKAGED MACHINE WEIGHTS				
Machine type		Carton	Wooden cage	Wooden case
KM343		Lbs 4255	Lbs 4652	

FIXING POINTS

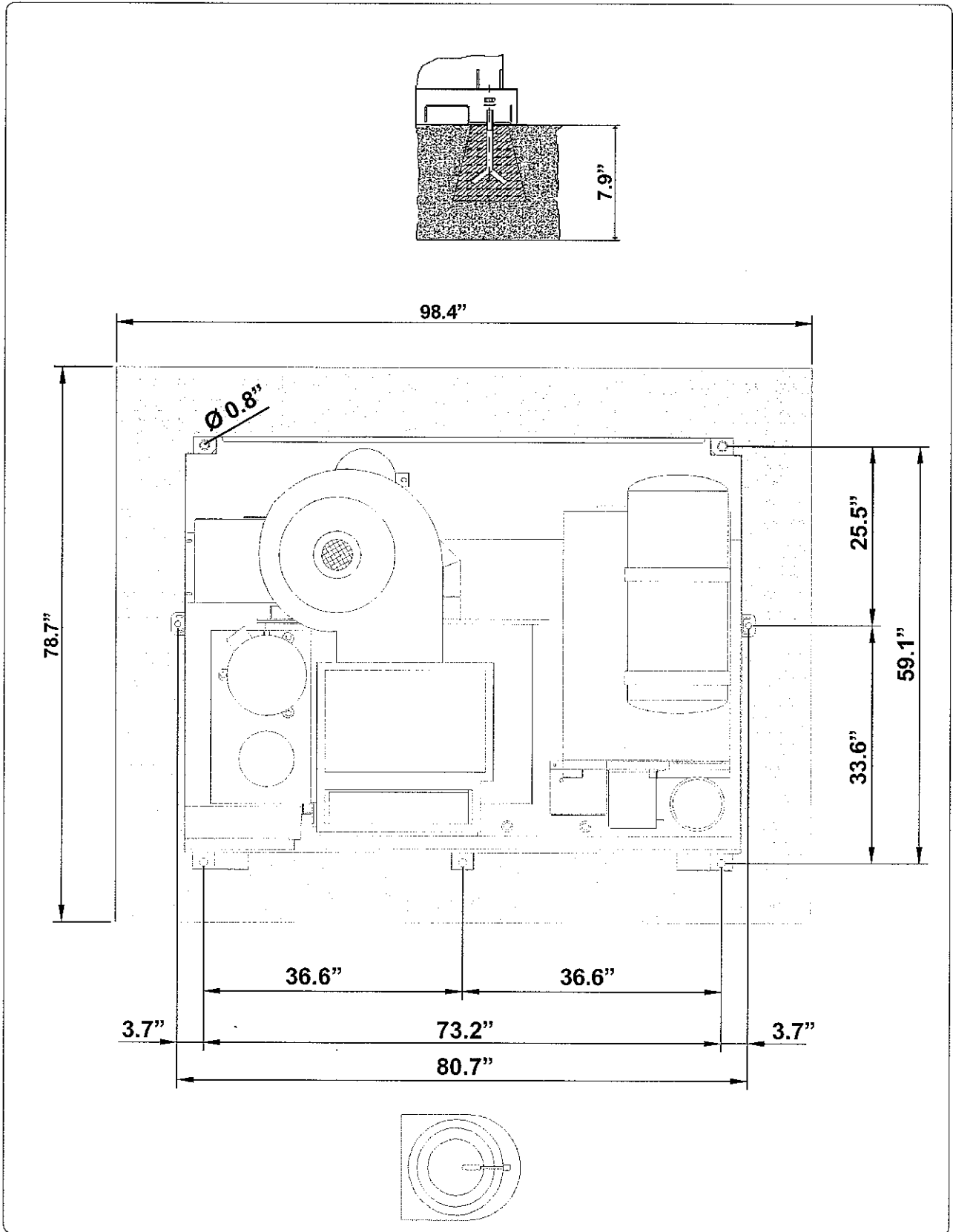

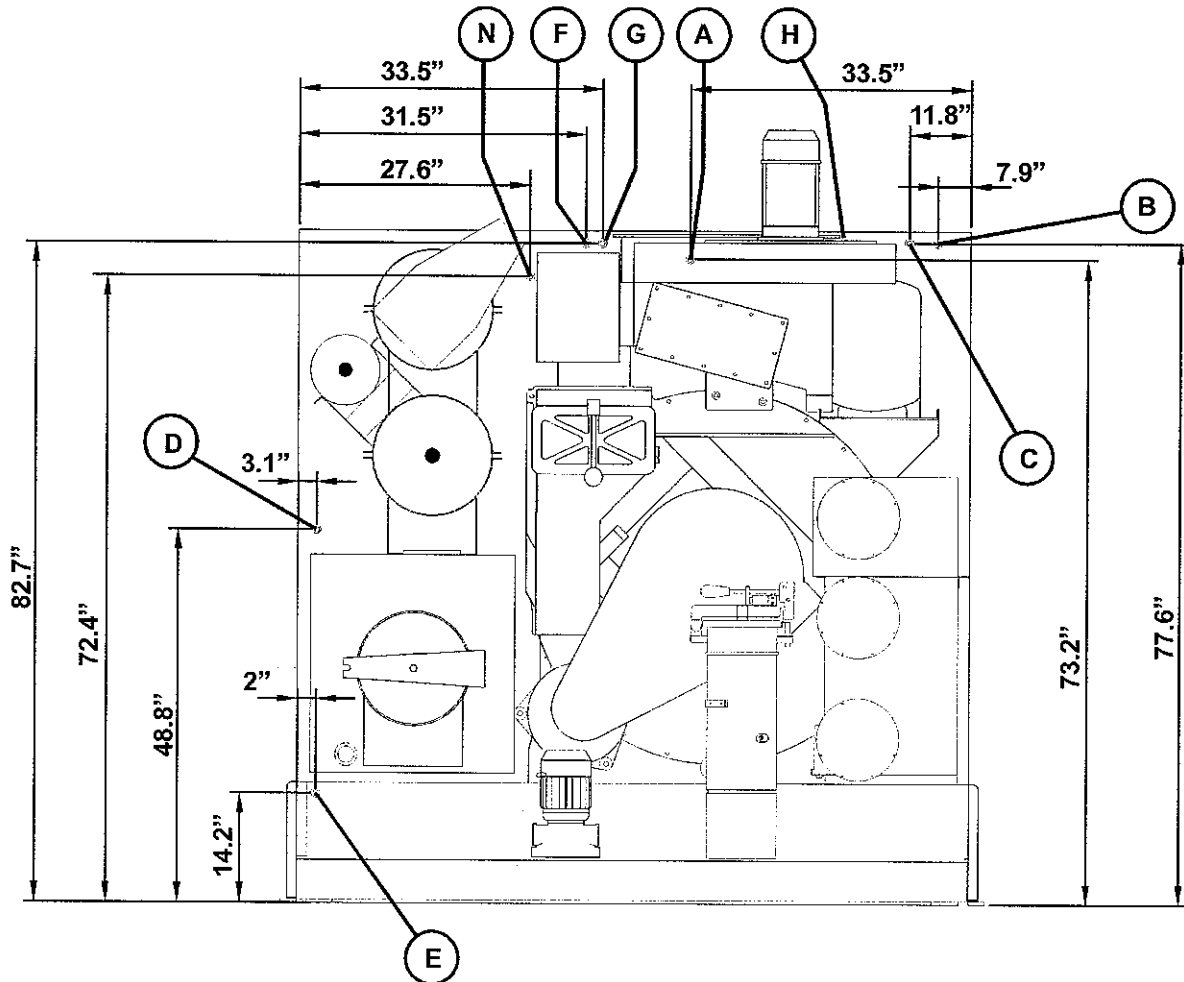
CONNECTIONS

A	Compressed air inlet	Ø 6 mm
B	Water inlet	Ø 1"
C	Water outlet	Ø 1"
D	Steam still inlet	Ø 1/2"
E	Condensate still outlet	Ø 1/2"
F	Steam heater inlet	Ø 1/2"
G	Condensate heater outlet	Ø 1/2"
H	Electric connection	
N	Nitrogen feeding connection (N ₂)	

SOLVENT TYPE		HYDROCARBON		
NECESSARY QUANTITY OF SOLVENT TO FILL THE MACHINE				
Machine Version - 04	gal	148	Lbs	948
Machine Version - 08	gal	140	Lbs	904
Machine Version - 10	gal	155	Lbs	992
Machine Version - 11	gal	155	Lbs	992

INFORMATION FOR THE ELECTRICAL CONNECTIONS (220 V - 60 Hz)				
ELECTRIC Version	Kw	-	Amp	-
STEAM Version	Kw	11.5	Amp	60.5

GENERAL INFORMATION		
Required water capacity	gal/min	3
Required water pressure	psi	40 ÷ 70
Required water temperature	°F	65° ÷ 70°
Required air pressure	psi	100 ÷ 115
Required steam pressure (Steam Version)	psi	55 ÷ 70
Required steam availability (Steam Version)	Lbs/h	132

